

Damper JK-A-07 G

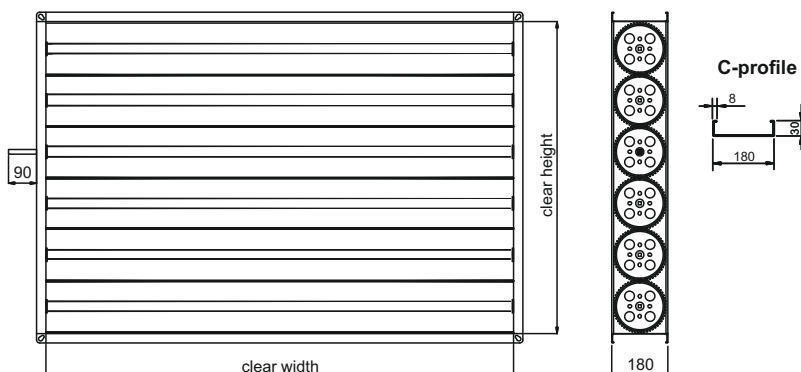

Multi-blade damper for air pressure and volume balancing and control in HVAC systems.

Description:

Blades:	Opposed-action airfoil blades made from galvanised steel with rubber edge seal; blade spacing 165 mm
Bearing:	Plastic-bearing
Drive mechanism:	Coupled in mid position, made from galvanised steel, 15 x 15 mm square, shaft extended 90 mm over frame, opening by turning counterclockwise. External gears made from special plastic, located at both ends of blade. Dampers with height from 1804 mm (11 blades) are pre-assembled with additional linkage tie rod
Frame:	Made from 1.5 mm steel plate, depth 180 mm, flange 30 mm, C-profile with corner borehole
Service temperature:	-20°C to +80°C
Airtightness:	Closed blade leakage in acc. with EN 1751 class 2

Variants:

- Powder-coating according to RAL-standard colour
- Gear cover single-sided or double-sided

Pneumatic actuator: When connecting a pneumatic actuator, a special drive arm and a counter bearing is required

Installation and Maintenance Instructions

1. Installation

- Pay attention to a tension-free and rectangular installation.
- Check the damper before installation and after tightening the flange screws to ensure that the blades open and close smoothly.
- This damper may be installed with vertical blades, if it is not intended for continual use applications. However, this will increase wear and tear due to pressure of the blades.
- Note, that the damper is to be kept free of ice when in service.

2. Operation

- Operate the damper with the drive shaft, only.

3. Maintenance

- The damper is maintenance-free and does not need lubrication. Clean the damper dry depending on the degree of soiling.

4. Accident hazard

- Keep hands out of the blades. Do not use blades for lifting of the damper. Risk of injury when touching gears, linkage and cut edges.

Damper JK-A-07 G

Technical Data

Corner hole layout
30 mm flange

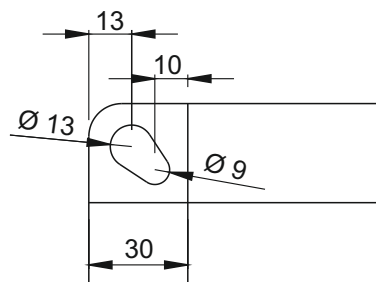

Damper coupling for width extension

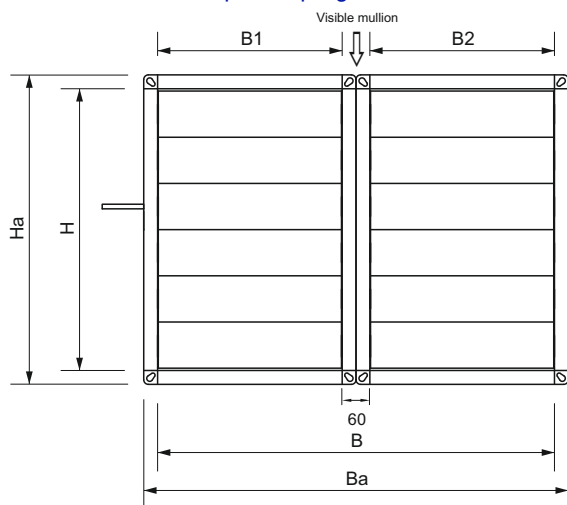

Bypass function

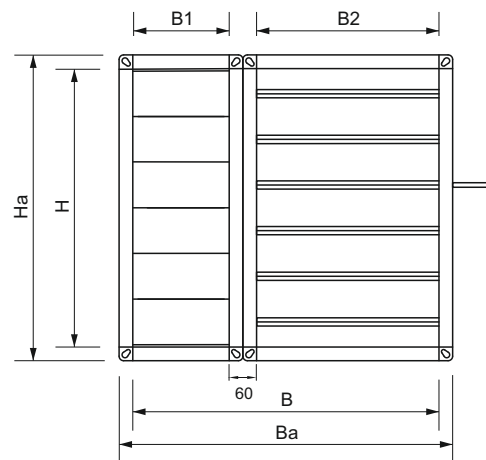

Visible mullion

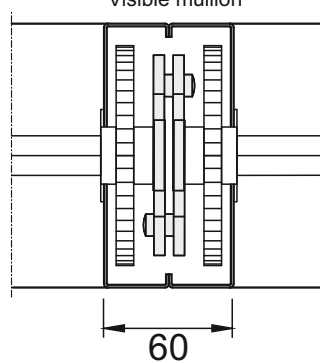

Damper JK-A-07 G

Technical Data

Motor mounting plate

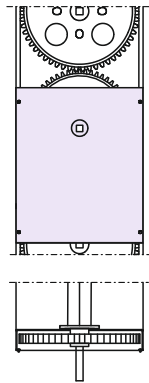

Manual adjustment lever with locking device

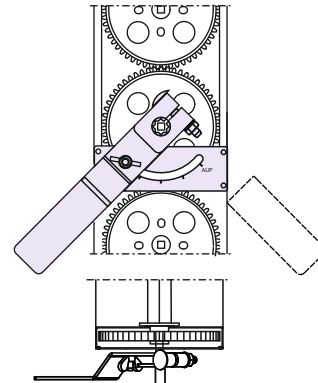

Linkage tie rod from H 1804 mm

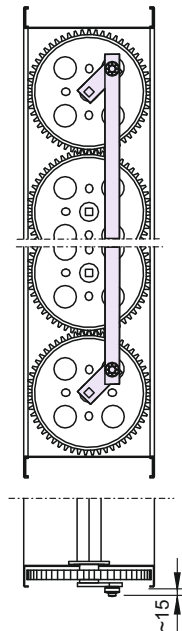

Counter bearing for drive arm for pneumatic actuator

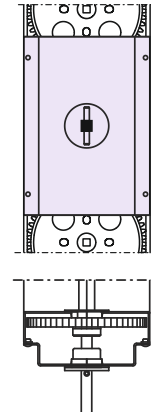

Damper JK-A-07 G

Technical Data

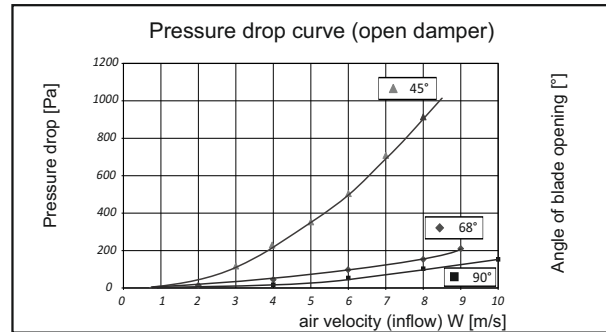
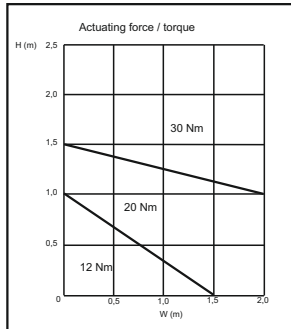

Maximum permissible pressure difference for dampers up to 2000 mm in width: 2000 Pa.

Leakage performance test in acc. with DIN EN 1751
Robert Geiger Technische Bauteile GmbH, Ichenhausen
Type JK-A-07 G

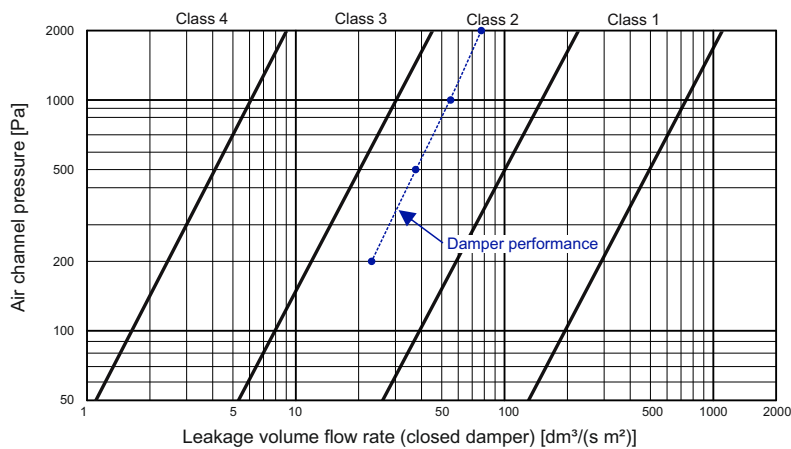

Tested dimensions: 1000 mm x 1000 mm
Testing approved by: TÜV NORD GmbH & Co KG, Germany