

Wall-mounted cantilever support arms

WK-LDB

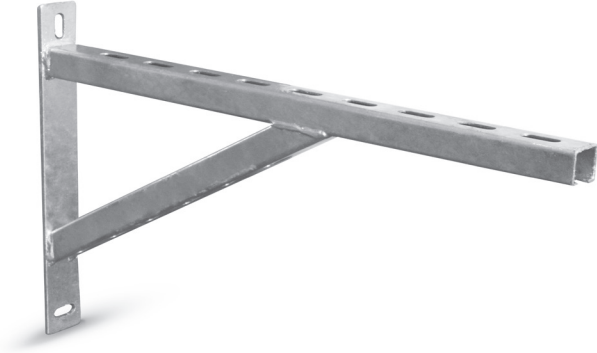

Description

WK-LDB cantilever support arms are designed for installing rectangular ventilation ducts directly along walls and for supporting heavy HVAC components, including A/C split indoor and outdoor units and AHUs. The additional bracing enhances the load capacity, permitting a wider clearance between the suspended installation parts and the walls.

Available materials - Product code example

WK-LDB-.....-..... - galvanized steel sheet

Product code example

Product code: **WK-LDB - 30 - 30 - 400**

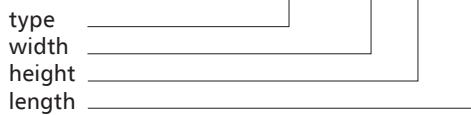

Dimensions

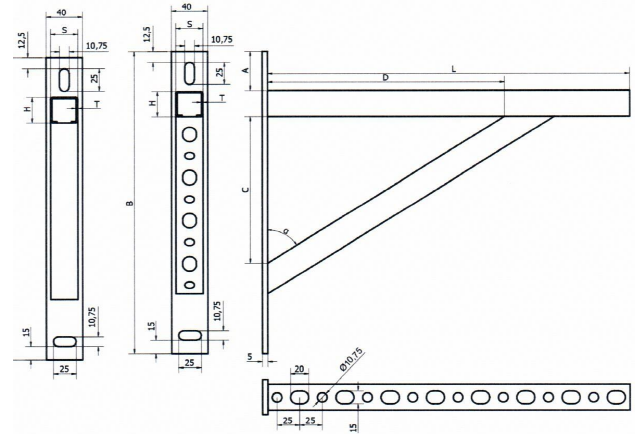

Product code	S	H	A	B	C	D	L
	[mm]	[mm]	[mm]	[mm]	[mm]	[mm]	[mm]
WK-LDB-30-30-400	30	30	42	350	160	245	400
WK-LDB-30-30-500	30	30	42	350	160	245	500
WK-LDB-30-30-600	30	30	42	350	195	320	600
WK-LDB-30-30-700	30	30	42	350	195	345	700
WK-LDB-30-30-800	30	30	42	500	265	425	800
WK-LDB-30-30-900	30	30	42	500	265	450	900
WK-LDB-30-30-1000	30	30	42	500	265	525	1000
WK-LDB-30-30-1200	30	30	42	500	350	600	1200
WK-LDB-41-21-400	41	21	42	330	160	245	400
WK-LDB-41-21-500	41	21	42	330	160	245	500
WK-LDB-41-21-600	41	21	42	330	195	325	600
WK-LDB-41-21-700	41	21	42	330	195	340	700
WK-LDB-41-41-400	41	41	42	370	160	245	400
WK-LDB-41-41-500	41	41	42	370	160	245	500
WK-LDB-41-41-600	41	41	42	370	195	325	600
WK-LDB-41-41-700	41	41	42	370	195	340	700
WK-LDB-41-41-800	41	41	42	500	265	425	800
WK-LDB-41-41-900	41	41	42	500	265	450	900
WK-LDB-41-41-1000	41	41	42	500	295	525	1000
WK-LDB-41-41-1200	41	41	42	500	350	600	1200
WK-LDB-41-41-1500	41	41	42	750	475	825	1500

Wall-mounted cantilever support arms

WK-LDB

Technical data

Maximum acceptable load capacity of WK-LDB cantilever support arm channels under point load

Support spacing L [mm]	Maximum load F [N]	
	WK-LDB-30-30	WK-LDB-41-41
400	1748	
500	971	
600	950	1130
700	594	
1200	220	
1500		420

Load diagram

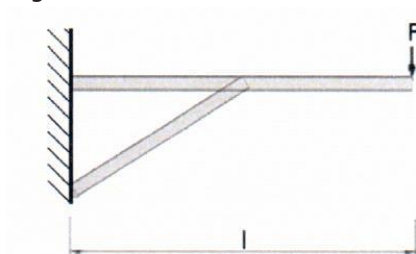

Maximum acceptable load capacity of WK-LDB cantilever support arm channels under continuous linear load

Support spacing L [mm]	Maximum load F [N]
	WK-LDB-30-30
400	3495
500	1942
600	1899
700	1324

Load diagram

